



professional tractor powered mowing equipment

Finally, a rotary mower has arrived that can truly match the cut performance of a cylinder.

*The **Trimax Merlin** offers an unrivalled combination of exceptional cutting ability, minimal maintenance and rugged durability. Leveraging off almost 30 years of experience designing and manufacturing rotary roller mowers for local authorities and councils, Merlin incorporates tried and trusted design principles as well as several exclusive new features. The result is a mower with unique abilities that will redefine attitudes and perceptions towards turf maintenance.*

Whether it be cutting thick, lush areas of rough or finely trimming an undulating, wet fairway at 12mm, the Merlin never fails to impress even the most avid cylinder mower enthusiast.



*Cuts as low as
12mm on fairways*

Contour following ability

Although Merlin does not offer individual decks for each spindle like some of its competitors, it achieves virtually the same result in terms of contour following ability thanks to the following features:

- Smallest blade cutting diameter in its class – this reduces the surface area being covered by the blade as it turns, therefore reducing the possibility of scalping;
- Full width front and rear rollers follow the contours of the ground and provide better consistency of cut height as opposed to castor wheels;
- Compact deck design helps prevent bridging;
- High degree of float per deck;
- Precision spindle placement achieves a high level of accuracy across the width of the mower;

Blade system

Merlin runs a higher blade tip speed and achieves even more cuts per forward metre of travel because the smaller diameter blades have less area to cover per revolution. This means that the 9 spindled Merlin makes 2,100 more cuts per minute than a 6 spindled mower of the same total cut width, contributing to an extremely clean cut finish whether it be on roughs or fairways.

Merlin also uses Trimax's exclusive Lazerbladez™ fling-tip blade system, common to all Trimax rotary mowers. Blade replacement is very simple and extremely inexpensive compared with other cutting systems.

Trimax LazerBladez™ are fitted as standard.



*Moving between locations is a safe and easy exercise.
Decks are hydraulically lifted and automatically locked into place for transport mode.*

world-leading rotary performance ... just add tractor!

Build quality

With vast experience designing and manufacturing mowing equipment for the local authority sector, Trimax understands the day to day realities of commercial turf maintenance. Hidden obstacles often lurk in good looking turf and the best operator can occasionally misjudge his distance from a tree. Merlin is designed to cope with these or to be easily repairable after a really serious misadventure. Only the highest quality materials and components are used to ensure total dependability at all times.

Trimax has developed a reputation for legendary build quality and has total confidence in every Merlin it manufactures. Each one is backed by a comprehensive 3 year, unlimited hours mechanical warranty.

Low maintenance

When buying new equipment, one of the most important considerations for any greens keeper or turf manager will be the ongoing time and cost involved to keep it in good working order. Trimax understands this well and has consequently developed a strong reputation for building machines that are simple and straight forward to maintain and repair. Maintenance features include:

Easy access: Unlatch each of the three deck covers for complete unobstructed access to all mechanical components..

Remote greasing: to roller bearings and spindles means no need to lift the covers for daily maintenance;

Cut height adjustment: Changing the cut height is a straightforward job, with cut height indicator blocks helping to ensure a consistent cut height setting across all of the decks;

Tensioning of drive belts: Belt tensions are adjusted with idler pulleys fitted concentrically with the blade spindle pulleys. The self clutching belt drive to the side decks is adjusted with an ingenious threaded boss that requires only one tool.

Blades: By raising the decks for transport mode, blades can be easily removed and replaced with one tool.

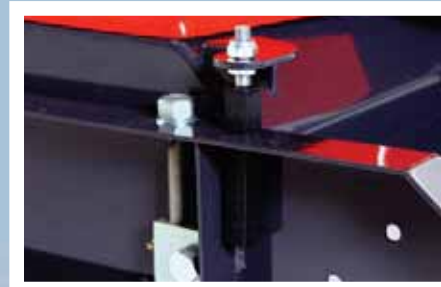

*Equally as capable
on roughs*

Other advantages of Merlin

- **Transport** – Merlin is designed to be safe and easy to transport behind a suitable towing vehicle, where local regulations permit. Load rated wheels, heavy duty road tyres and independent dura-torque suspension all come as standard. LED road lighting is a recommended option for those needing to transport Merlin on public roads.
- **Low noise** – the Merlin is exceptionally quiet, meaning the operator can worry less about causing a distraction to people whilst mowing.
- **Striping** – rollers help produce a superb striping effect, which is popular for those that wish to pattern their turf.
- **Low cost, easy maintenance** – Frequent greasing of roller bearings, drive shafts and spindles are all that's needed to keep the Merlin in peak condition. Blades, drive belts and roller bearings will need to be replaced occasionally.
- **Safety** – full width front and rear rollers effectively block off the area where solid objects could be ejected if hit by the blades. All mechanical components and moving parts cannot be reached without unlocking the covers. Merlin also offers positive automatic deck locking when in transport mode, and has a low centre of gravity for greater stability when mowing on steep slopes.



Options

- LED Road Lighting
- Ribbed Turf Tyres
- Side Channel Wear Pads
- Anti-bounce Skids
- Drawbar Clevis
- Solid Roller Scrapers
- Electric Brakes (note: cannot be fitted with turf tyres)
- Hydraulic Powered Sliding Drawbar

Specifications

The manufacturer has a policy of continuous improvement, therefore specifications may change without notice.

DESIGNED & MANUFACTURED IN
NEW ZEALAND

- (A) Transport**
Independent road suspension
LED road lighting (optional)
Heavy duty road tyres
High load rated alloy wheels
Decks raise hydraulically and automatically lock for transport
Configured for road use

- (B) Transmission**
Self clutching triple belt drive to left and right hand decks
Simple tightening by way of a threaded boss which requires only one tool

- (C) Covers**
Strong moulded fibreglass covers provide outstanding safety and full protection from moving parts
Simply unlatch the gas strutted covers to gain unrestricted access to the entire drive system

- (D) Mowing Decks and Rollers**
5mm steel and monocoquular construction
High underbody clearance copes with greater volume of grass
Unique baffle design for even discharge
Independent float enables full articulation and contour following
Anti bounce skids (optional)
Large diameter rollers front and rear help prevent scalping and give a superb striping effect

- (E) Cutting Height**
Infinitely variable within cut height range (10-100mm)
Cut height indicators for easy visual checking of cut height

- (F) Spindles**
Trimax's famous tapered spindle for extreme reliability
High tensile shafts
Labyrinth seals
Heat treated alloy housings
Remote greasing without lifting covers
Three year warranty

- (G) Blades**
Trimax's proven Lazerbladez™ fling tip system
Small diameter for more cuts per forward metre of travel
Special alloy steel for longer life

- (H) Chassis**
Strong box section construction
Extra plated in high stress areas
Drawbar adjustable for compact storage

ML 320

Cutting Width	3.25m (10' 8")
Overall Width	3.39m (11' 1")
Transport Width	1.79m (5'10")
Overall Length	3.06m (10')
Cut Height Range	10 – 100mm (¾" – 4")
Approx Weight	1200kg (2645lb)
Minimum Power ¹	22kW (30hp)
Maximum Power	45kW (61hp)

¹ For light cutting on level ground only

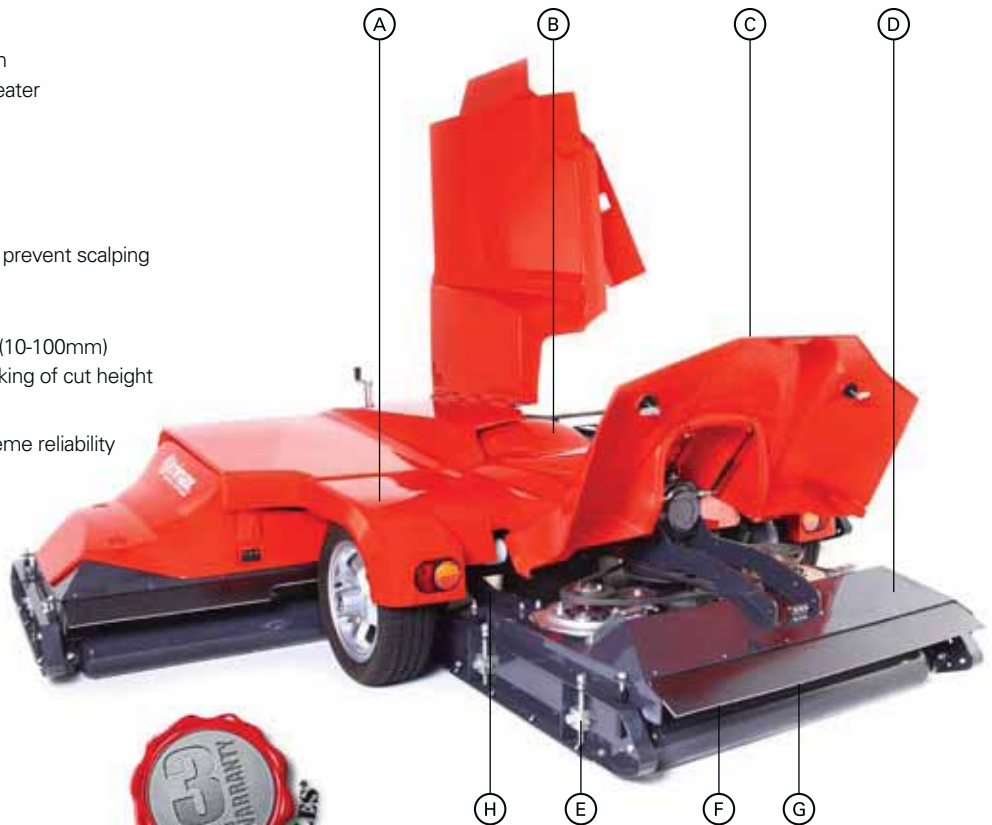

FITTED WITH **LazerBladez™**

insist on Trimax
Genuine Parts

WARNING: Machinery shown in this publication may have protective guards removed for demonstration purposes. Trimax strongly recommends the use of safety guards and shields during normal operation to reduce the risk of property damage, serious bodily injury or even death from objects thrown out by, or from contact with the cutting blades.



www.trimaxmowers.com

New Zealand

70 Maleme Street
PO Box 2150, Tauranga 3041
New Zealand

phone: +64 7 541 0411 (SALES/ADMIN)
phone: +64 7 543 1897 (PARTS)
fax: +64 7 541 0412

email: sales@trimaxmowers.co.nz

United Kingdom

Unit 11B, Hill Farm Estate, Irthlingborough Road
Little Addington, Kettering, Northamptonshire
NN14 4AS, United Kingdom

phone: 01933 652235 (SALES/ADMIN)
phone: 01933 652246 (PARTS)
fax: 01933 652254

email: info@trimaxmowers.co.uk

Your nearest authorised dealer:

